

# Hyatt Place North Shore Pittsburgh, PA



Thesis Proposal

Kyle Tennant

Structural (IP)

Dr. Ali Memari



December 10 2010

## Table of Contents

I.	Executive Summary.....	3
II.	Introduction.....	4
III.	Structural System Overview.....	5
	a. Foundation.....	7
	b. Gravity System.....	7
	c. Lateral System.....	11
IV.	Codes and Design Standards.....	12
V.	Materials.....	13
VI.	Proposal Statement.....	14
VII.	Proposal Solution.....	15
VIII.	MAE/BAE.....	16
IX.	Breadth 1 – Architecture and Aesthetics.....	16
X.	Breadth 2 – Cost and Schedule.....	16
XI.	Tools and Tasks.....	17
XII.	Schedule.....	19

## Executive Summary:

The purpose of this report is to present and explain the proposed thesis study for the Hyatt Place North Shore, located in Pittsburgh, PA. After analyzing the existing structural system of the 7-story Hyatt Place North Shore it is determined that it is sufficient to carry the load and meet code standards. The 70 feet tall, 108,000 square foot structure has intermediate reinforced concrete masonry bearing walls working in combination with an 8" un-topped precast concrete plank floor structure to handle both gravity and lateral loads down into the soft soils along the Allegheny River and to bedrock approximately 70 feet below with numerous 18" diameter auger piles.

The Hyatt Place North Shore is an "L" shape that has an abundance of shear walls around its perimeter and along the double loaded corridor that runs down the middle of each leg, thus the center of rigidity is expected to be near the center of mass. But in general the "L" shape leads to the legs individually being better at resisting forces in a specific direction and then one side of the building could deflect a significant amount more than the other. There would have to be special considerations for this building shape if the building was purposed for a location in the Western United States where seismic load is much greater. Ideally a large "L" shaped building would have a separation joint large enough to allow the two legs of the building to act independently from each other limiting the twisting action due to the orientation of shear walls. Thus the building shape leads to the thesis study for the Hyatt Place North Shore.

The proposed thesis study is to have the building relocated to California and redesigned to best meet to the seismic loads given the building layout. This will require a complete redesign of the gravity and lateral force resisting systems. The gravity structure will be steel with topped precast concrete plank floor system and the lateral system will be steel braced and moment frames along with concrete shear walls around stairwells. These systems will be designed in RAM and ETABS and checked for validity by hand. Two or three lateral force resisting frames will be designed by hand in order to incorporate my MAE courses.

With the redesign of the superstructure, the cost and schedule of the building will be affected, along with the building enclosure. Both topics will be analyzed and used to compare the effect of location on the building as a whole. The use of the separation joint between wings of the building will also be compared. All of this information will be compiled to compare the Pennsylvania location with the California location.

## Introduction:

The Hyatt Place Hotel is part of an agreement between the Pittsburgh Steelers and Pirates that began back in 2003 with the goal to bring commercial development to the North Shore. The 108,000 SF, 178 room hotel is conveniently close to both of the teams' stadiums, Rivers Casino, and Pittsburgh in general.



Figure 1: Areal view of the North Shore courtesy of Bing.com

The first floor has all the expected guest amenities along with an indoor pool, lounge space, and generously sized meeting rooms. The first floor has a ceiling height of 17'-4" and the upper floors are 8'-0". Maximum floor to ceiling height is obtained with an 8 inch thick hollow core concrete plank floor system and through the use of PTACs in guestrooms. Floors 2 through 7 house 67,388 SF Net Guestroom in 178 rooms. All rooms are well sized with a partition dividing the sleeping and living spaces. Rooms are furnished with 42 inch high definition flat screen TVs and a well-designed work and entertainment center along with hotel wide Wi-Fi.



Figure 2: South Elevation

Exterior elevations are mainly comprised of brick veneer cavity wall system with rigid insulation and structural CMU backup along with cast stone window headers, some strips of aluminum, metal plates, cast stone, and polished block in a way to complement the modern look of the interior. The parapet wall also varies in height from 3 feet to 9 feet creating interesting snow and wind loadings on the roof that will be examined in the Building Load Summary section of the report on page 13. The roof is a typical TPO membrane roof system.

## Structural System Overview

The Hyatt Place North Shore is a 7 story reinforced concrete masonry bearing structure located on soft soils along the Allegheny River that utilizes precast concrete planks for ease of construction and headroom. Steel beams are used to create an open space on the ground floor for a large meeting room and in other various places where the layout makes it impossible for the concrete planks to rest on the typical masonry bearing walls, shown in *Figure 3*. The reinforced concrete masonry bearing walls also serve as the lateral force resisting system with the aid of the precast concrete planks acting as a semi-rigid diaphragm.



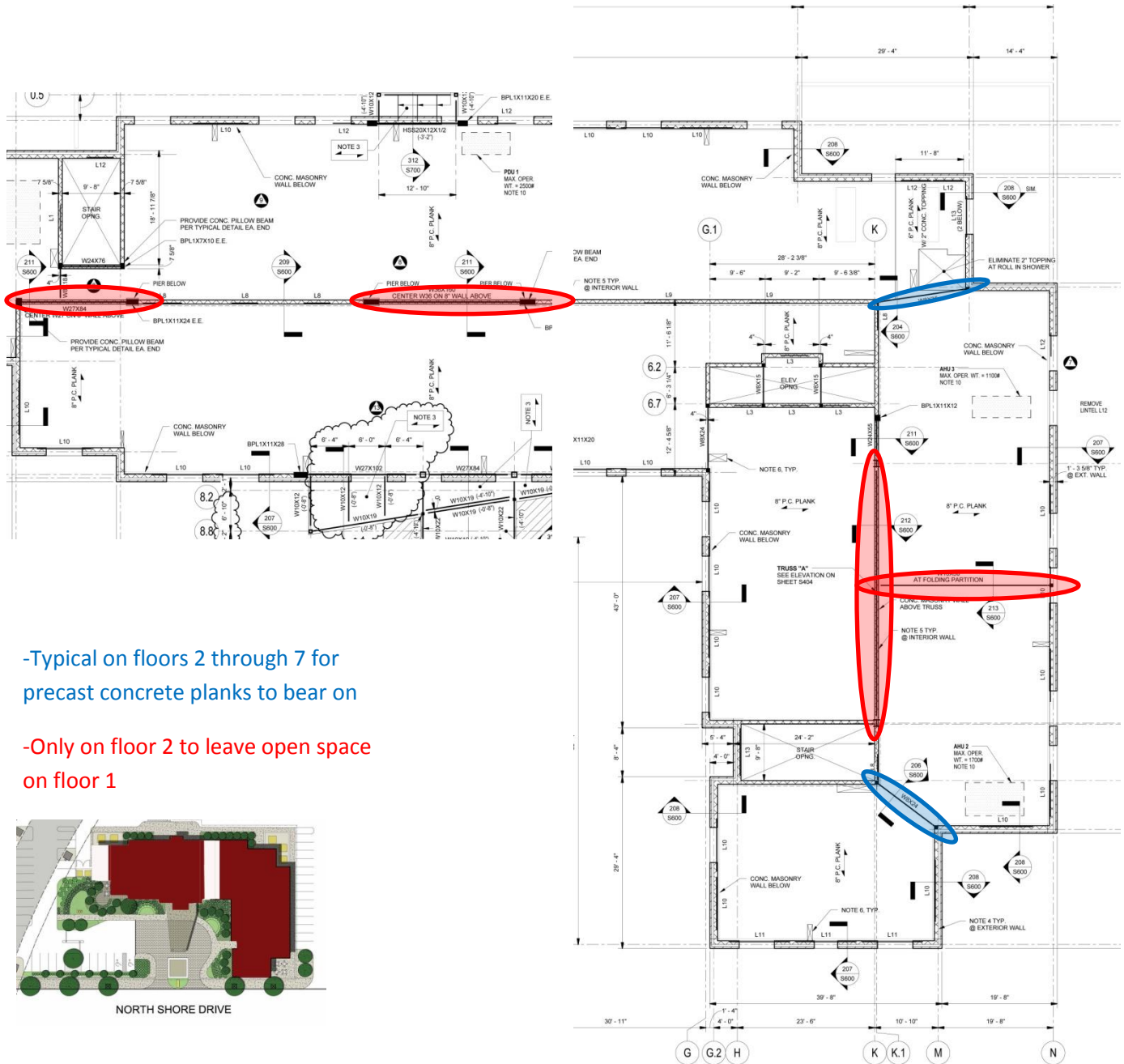
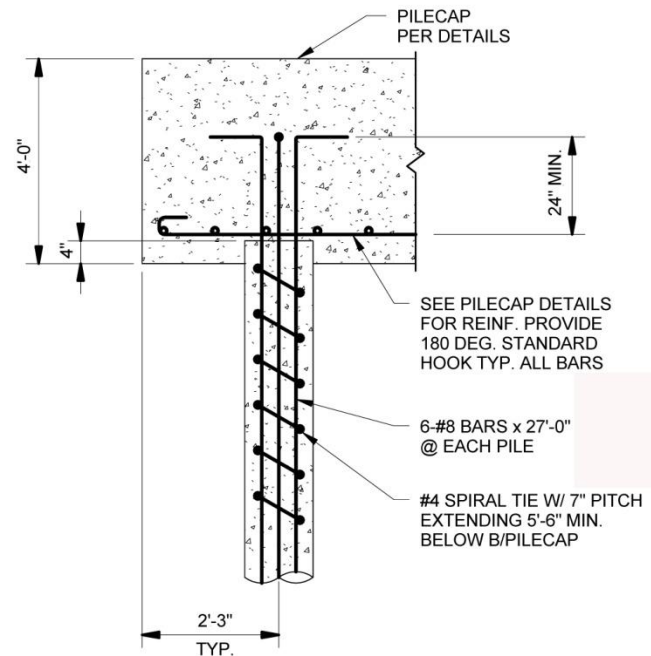

Figure 3: View of steel beams used

## Foundation:

The Hyatt Place North Shore has a 15,500 SF footprint located on soil along the Allegheny River that has a maximum allowable bearing capacity of 1,500 psf. Spread footings have been provided for the front canopy, 5'-0" x 5'-0" x 1'-0" concrete spread footing with a maximum load of 25 kips, and site wall foundations only. There are 121 – 18" diameter end bearing 140 ton auger-cast piles that have a minimum depth of 1'-0" into bedrock to support the building. They have a 285 kip vertical capacity and a 16 kip lateral capacity. Piles are typically expected to be 70 feet deep, but this varies per pile. As shown in *Figure 4*, pile caps are 4'-0" thick. There are 2 to 4 piles supporting each pile cap. All concrete used for shallow foundations and piers have a strength of 3000 psi and the concrete for grade beams, pile caps, and slabs on grade are 4000 psi. The first floor is a 4" concrete slab on grade with W/ 6x6-W1.4xW1.4 welded wire fabric.



### TYPICAL SECTION THRU PILECAP

Figure 4: Section through typical pile cap

## Gravity System

### Walls:

Nearly all of the walls in the Hyatt Place North Shore are reinforced concrete masonry walls that resist gravity and lateral loads. The only exceptions are partition walls between the hotel rooms and other random walls not along the perimeter of the building. The walls vary in thickness and spacing of grout and reinforcing, *Table 1* shows the wall types and location. The compressive strength of the CMU units is 2800 psi and the bricks are 2500 psi, both normal weight. The grout used has a compressive strength of 3000 psi and the steel reinforcement is sized and placed as stated in *Table 1*. *Figure 5* shows the orientation of the walls on a typical upper level plan, the capacity of each of these wall types can be determined. *Table 2 & 3*, and *Figure 6* show the typical lintel in a masonry bearing wall.

Reinforced Concrete Masonry Bearing Wall Schedule								
Wall Type	Thickness	Rebar	Spacing	Grout	Floor Location	Weight (psf)		
						CMU & Grout	Rebar	Total
A	12"	#7	16" O.C.	All cells	1st ext.	140	1.53	141.53
B	12"	#7	32" O.C.	All cells	1st int. center	140	0.77	140.77
C	8"	#6	32" O.C.	All cells	1st int. random	92	0.56	92.56
D	8"	#6	24" O.C.	Cells w/reinforcement	2nd ext.	69	0.75	69.75
F	8"	#5	32" O.C.	All cells	2nd int. typ.	92	0.39	92.39
G	8"	#6	32" O.C.	16" O.C.	3rd - 5th ext.	75	0.56	75.56
H	8"	#6	32" O.C.	Cells w/reinforcement	5th - 7th ext.	65	0.56	65.56
I	8"	#5	32" O.C.	16" O.C.	3rd - 5th int.	75	0.39	75.39
J	8"	#5	32" O.C.	Cells w/reinforcement	5th - 7th int.	65	0.39	65.39

Table 1: Reinforced concrete masonry bearing wall schedule

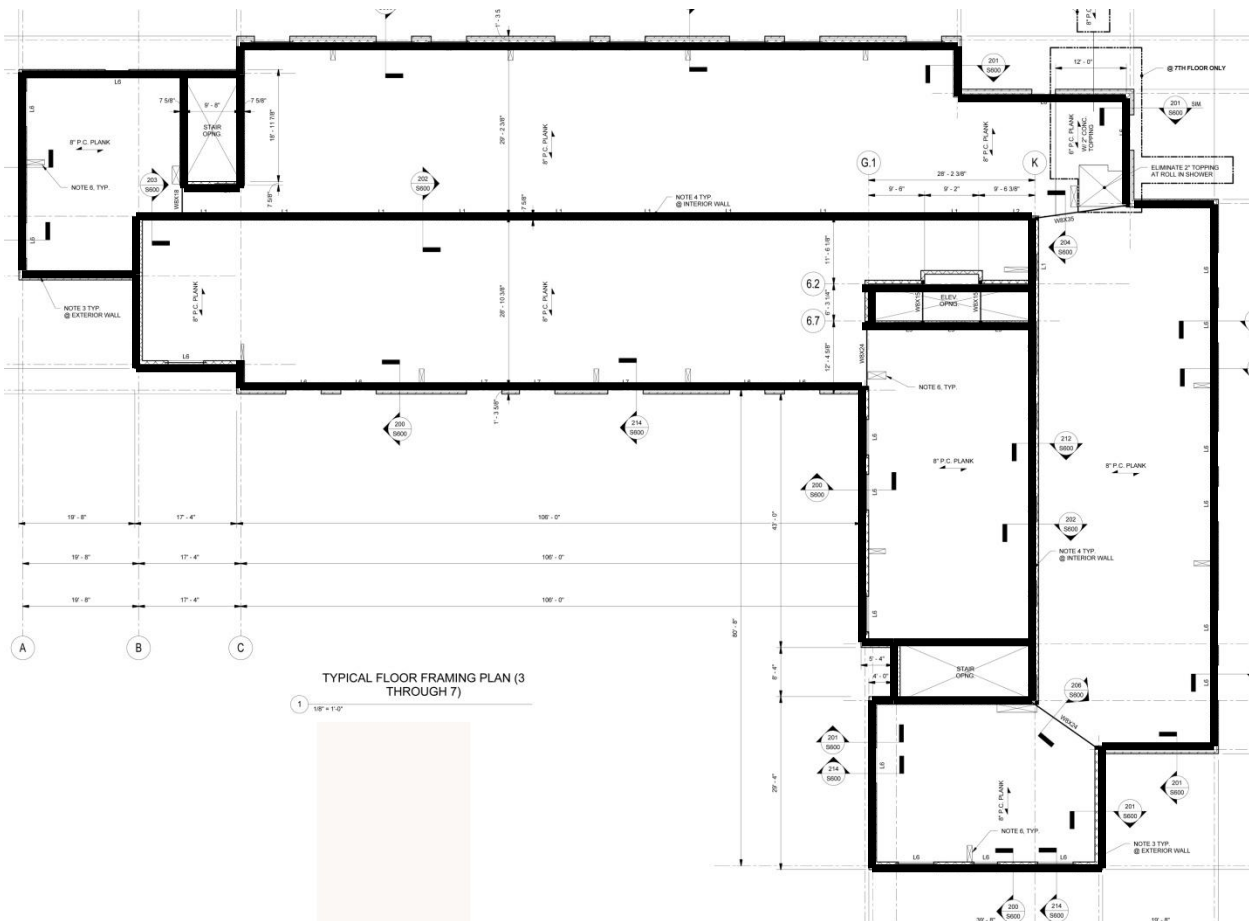

Figure 5: Typical bearing wall layout, floors 3 through 7



PRECAST LINTEL SCHEDULE FOR LOAD BEARING MASONRY WALLS						
MARK	SIZE	MAX. M.O.	LOADING LBS/FT		REMARKS	MARK
			LIVE	DEAD		
L1	8"	3'-4"	2000	1800	SEE "TYP. LINTEL DETAIL 1"	L1
L2	8"	6'-4"	2000	1800	SEE "TYP. LINTEL DETAIL 1"	L2
L3	10" VERIFY W/ELEV. MFR.	3'-6"	500	500	SEE "TYP. LINTEL DETAIL 1"	L3
L4	8"	6'-0"	1400	400	SEE "TYP. LINTEL DETAIL 2"	L4
L5	8"	6'-0"	1400	400	SEE "TYP. LINTEL DETAIL 4"	L5
L6	8"	6'-0"	1000	1000	SEE "TYP. LINTEL DETAIL 2"	L6
L7	8"	6'-0"	1000	1000	SEE "TYP. LINTEL DETAIL 4"	L7
L8	8"	6'-0"	1000	1000	SEE "TYP. LINTEL DETAIL 1"	L8
L9	8"	3'-4"	1000	1000	SEE "TYP. LINTEL DETAIL 1"	L9
L10	16"	6'-4"	2100	1000	SEE "TYP. LINTEL DETAIL 3"	L10
L11	16"	9'-4"	2100	1000	SEE "TYP. LINTEL DETAIL 3"	L11
L12	8"	5'-0"	1500	1000	SEE "TYP. LINTEL DETAIL 2"	L12
L13	16"	7'-0"	2600	1000	SEE "TYP. LINTEL DETAIL 2"	L13

PRECAST LINTEL FOR LOAD BEARING MASONRY WALLS NOTES:

- MASONRY OPENINGS SHOWN IN SCHEDULE ARE MAXIMUM ALLOWED FOR LINTEL. SEE ARCH. DWGS. FOR ACTUAL MASONRY OPENINGS DIMENSIONS.
- PROVIDE MIN. 8" BEARING ON BRICK OR SOLID CONC. BLOCK.
- PRECAST LINTEL MFR. TO DESIGN PRECAST LINTELS FOR LOADS SHOWN IN SCHEDULE. SEE GENERAL NOTES FOR ADD'L INFO. LOADS ARE UNFACTORED.
- SEE BRICK SUPPORT LINTEL SCHEDULE FOR ANGLE SIZE NEEDED FOR MASONRY OPENING.
- LINTEL MUST BE DESIGNED FOR A MAXIMUM TOTAL LOAD DEFLECTION LESS THAN 0.3" OR SPAN/600.

**Table 2:** Precast Lintel schedule for load bearing masonry walls

BRICK LINTEL SCHEDULE			
WALL THICKNESS	MASONRY OPNG. UP TO 4'-0"	MASONRY OPNG. 4'-0"+ TO 6'-0"	MASONRY OPNG. 6'-0"+ TO 8'-0"
4" WALL	BENT PL5/16x5 1/2x3 1/2 LLH	BENT PL5/16x5 1/2x4 LLH	BENT PL5/16x5 1/2x5 1/2

NOTES:

- PROVIDE MINIMUM 6" BEARING ON BRICK.

**Table 3:** Brick lintel schedule

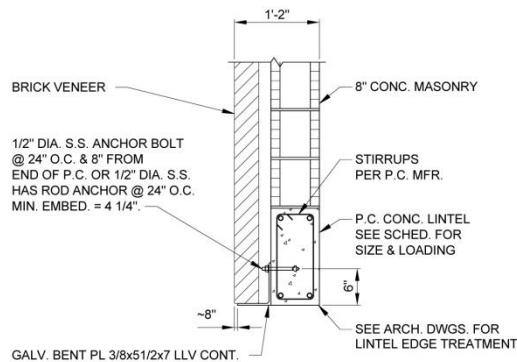

**TYPICAL LINTEL DETAIL "3"**

**Figure 6:** Typical lintel detail

**Columns:**

With the masonry structure, the only 2 columns in the building are W12x136s located on the first floor and are used to transfer the load in the large transfer girder down to the foundation, *Figure 7*. There are also concrete masonry piers on the first floor that support transfer beams in the lobby space and make it possible to have more window space on the first floor.

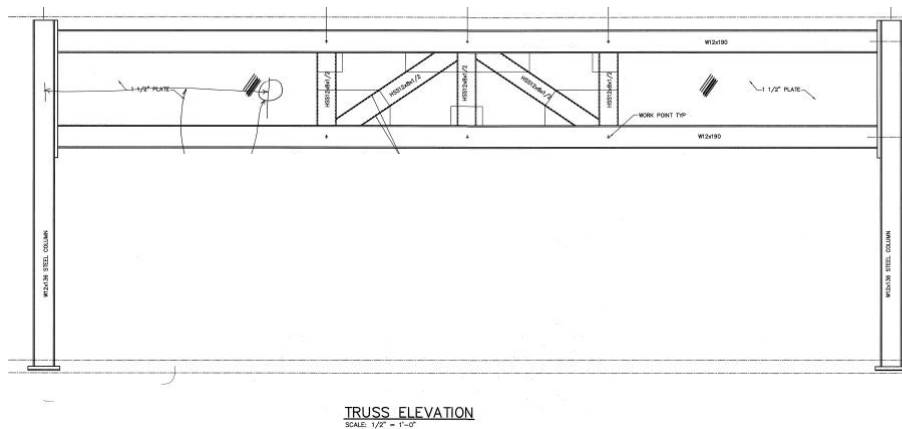

**Figure 7:** Transfer girder in first floor meeting space

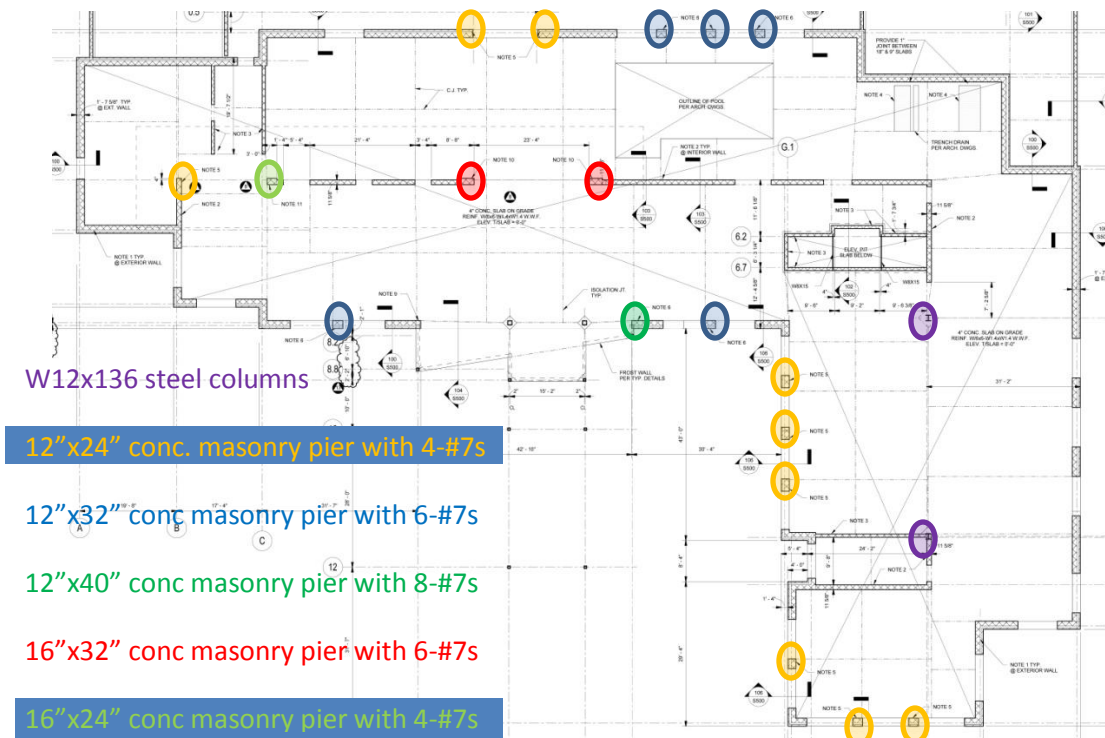

**Figure 8:** Location of masonry piers on first floor

## Floors:

The Hyatt Place North Shore floor system is 8" thick untopped precast concrete planks. This system simplifies design and expedites construction. The system efficiently carries the loading over relatively long spans ranging from 27'-6" to 30'-6". The concrete compressive strength of the floors is  $f'_c=5000$  psi. Extra strength is also added by prestressing the units. *Figure 12* shows a typical connection with masonry bearing walls.

The only exception to the typical concrete plank floor is on the first floor where this is a 4 inch concrete slab on grade, which was previously discussed on page 6 in the foundations section.

As previously stated on page 4 and denoted in

*Figure 3*, steel beams are used in places where there is an opening in the interior bearing wall on the first floor and on all floors as needed for the planks to bear on. The members used are W8x18, W8x24, W8x35, W36x160, and W27x84. The large steel truss spanning 44'-4" over the meeting rooms 2 – W12x190s that are spaced 5' apart with HSS members and 1 1/2" steel plate webbing.

## Lateral System

The lateral system for the structure is simply the gravity system. The reinforced masonry bearing walls depicted in *Figures 5 & 6* on page 7 act as shear walls and the precast concrete planks act as a semi-rigid diaphragm compared to cast-in-place concrete floor. The existing system only has a leveling material added, for planks to be considered fully rigid there must be a 2" structural concrete topping. The loads travel into the diaphragm and then into the bearing walls and down to the foundation and the auger piles that are capable of resisting 16 kips of lateral force per pile.

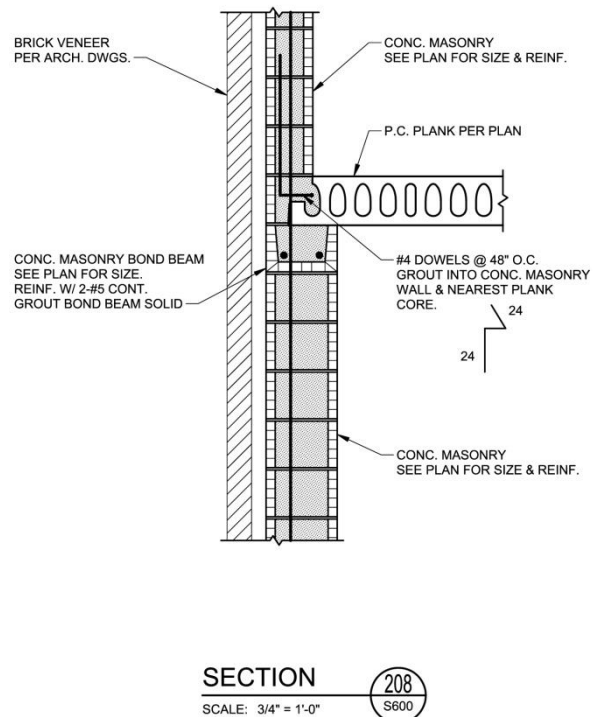

Figure 9: Typical plank and masonry wall connection

## Codes and Design Standards

### Codes:

The following references were used by the engineer of record at Atlantic Engineering Services to carry out the structural design of the Hyatt Place North Shore

- The International Building Code 2006 – Amendments City of Pittsburgh
- The Building Code Requirements for Structural Concrete (ACI 318-05), American Concrete Institute
- PCI MNL 120 “PCI Design Handbook – Precast and Prestressed Concrete”
- The Building Code Requirements for Masonry Structures (ACI 530), American Concrete Institute
- Specifications for Masonry Structures (ACI 530.1), American Concrete Institute
- Specifications for Structural Steel Buildings (ANSI/AISC 360-150), American Institute of Steel Construction
- Minimum Design Loads for Buildings and Other Structures (ASCE 7-05), American Society of Civil Engineers
- ETABS Modeling and Analysis – Computer & Structure, Inc.

### Drift Criteria:

The following allowable drift criteria found in the International Building Code, 2006 edition.

- Allowable Building Drift:  $\Delta_{wind} = H/400$
- Allowable Story Drift:  $\Delta_{seismic} = .015H_{sx}$

### Load Combinations:

The following load cases from ASCE 7-05 section 2.3 for factored loads using strength design; the greyed out portions don't apply in this case. These load combinations were considered in the ETABS model to determine the controlling case for the N/S and E/W directions.

- 1.4 (D + F) COMBO1
- 1.2 (D + F + T) + 1.6(L + H) + .5(L<sub>r</sub> or S or R) COMBO2
- 1.2D + 1.6(L<sub>r</sub> or S or R) + (L or .8W) COMBO3
- 1.2D + 1.6W + L + .5(L<sub>r</sub> or S or R) COMBO4
- 1.2D + 1.0E + L + .2S COMBO5

- .9D + 1.6W + 1.6H COMBO6
- .9D + 1.0E + 1.6H COMBO7 (controls for X & Y-Direction)

## Materials

### Concrete:

Shallow Foundations and Piers	3000 psi
Grade Beams and Pile Caps	4000 psi
Slabs on Grade	4000 psi
Precast Concrete Planks	5000 psi

### Rebar:

Deformed Bars Grade 60	ASTM A615
Welded Wire Fabric	ASTM A185

### Masonry:

Concrete Masonry Units	2800 psi
Bricks	2500 psi
Grout	3000 psi

### Structural Steel:

W Shapes	ASTM A992,	Fy = 50 ksi	Fu = 65 ksi
Channels	ASTM A572 Grade 50	Fy = 50 ksi	Fu = 65 ksi
Tubes (HSS Shapes)	ASTM 500 Grade B	Fy = 46 ksi	Fu = 58 ksi
Pipe (Round HSS)	ASTM 500 Grade B	Fy = 46 ksi	Fu = 58 ksi
Angles and Plates	ASTM A36	Fy = 36 ksi	Fu = 58 ksi



## Problem Statement

After analyzing the existing structural system of the 7-story Hyatt Place North Shore it is determined that it is sufficient to carry the load and meet code standards. The 70 feet tall, 108,000 square foot structure has intermediate reinforced concrete masonry bearing walls working in combination with an 8" un-topped precast concrete plank floor structure to handle both gravity and lateral loads down into the soft soils along the Allegheny River and to bedrock approximately 70 feet below with numerous 18" diameter auger piles.

The Hyatt Place North Shore is an "L" shape that has an abundance of shear walls around its perimeter and along the double loaded corridor that runs down the middle of each leg, thus the center of rigidity is expected to be near the center of mass. But in general the "L" shape leads to the legs individually being better at resisting forces in a specific direction and then one side of the building could deflect a significant amount more than the other, *Figure 10*. Ideally a large "L" shaped building would have a separation joint large enough to allow the two legs of the building to act independently from each other limiting the twisting action due to the orientation of shear walls, *Figure 10*. There would have to be special considerations for this building shape if the building was purposed for a location in the Western United States where seismic load is much greater.

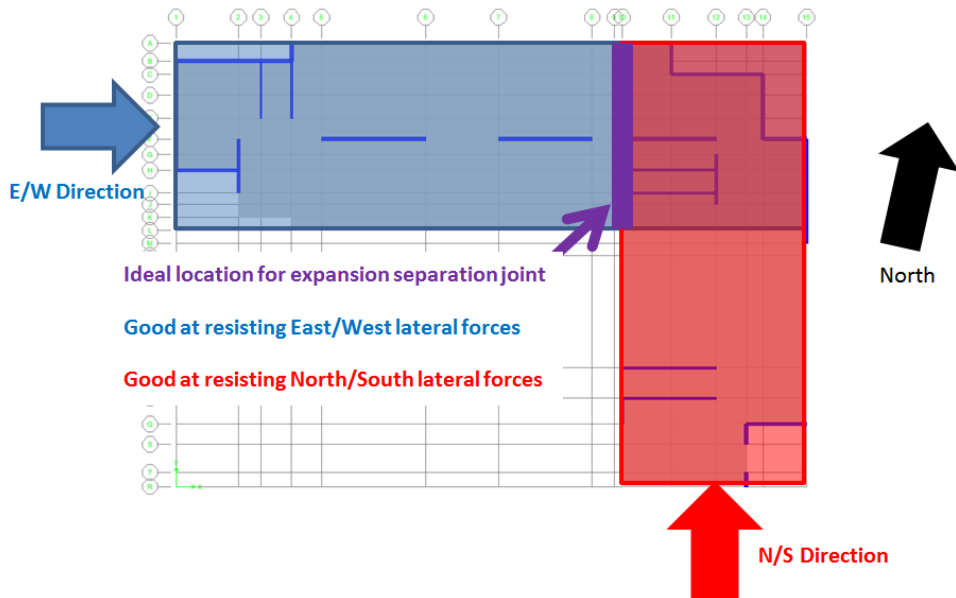

Figure 10

## Proposed Solution

*Theme: Relocation to high seismic region – redesign as two separate steel frame structures with a separation joint in between.*

The Hyatt Place North Shore will be relocated to California in order to study the effects of building shape in high seismic regions. In order to achieve this goal the gravity and lateral system will be redesigned in steel. The steel system provides a lighter overall building weight and a higher R-value which will minimize the seismic base shear. The wings of the building will also be isolated and designed separately with new lateral force resisting systems and compared to how the building acts without a separation joint. Isolation and new layout of lateral force resisting elements will limit the effects of torsion and building twisting action. A new seismic base shear will be calculated and the old wind calculations will remain the same because the overall building height with the new system is expected to remain the same.

The gravity system will be a composite steel and precast plank system, this was an alternative system analyzed in technical report 2. This system uses an open-web dissymmetric beam or “D-Beam” to allow the concrete planks to be concealed in the depth of the girder. After the topped precast concrete planks are placed and grout is filled in, the girder slab system develops

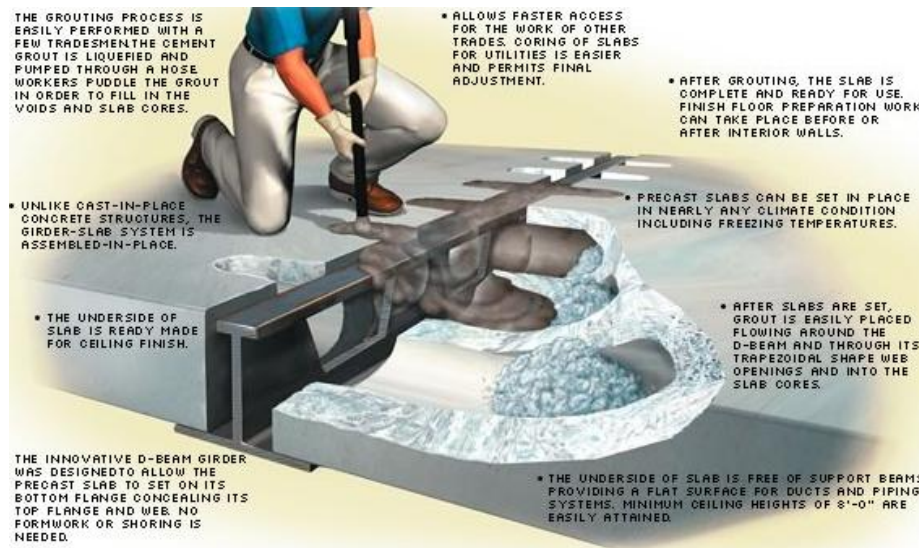

Figure 10: Composite steel and precast concrete plank system

composite action. This enables a smaller girder to carry more load and the floor to act as a uniform rigid diaphragm, as opposed to the existing un-topped semi-rigid diaphragm, Figure 11.

The lateral system will use the concrete shear walls in place of the existing intermediate reinforced masonry shear walls that surround the stairwells. The remainder of the shear walls will be removed and replaced by concentric braced frames, eccentric braced frames, and moment frames in strategic locations to best limit the building torsion.

## **MAE/BAE**

Knowledge learned from my masters courses such as Computer Modeling and Earthquake Resistant Design of Buildings will be used in the redesign of the Hyatt Place North Shore for a location in California. The first of which will be in the creation of models in both RAM and ETABS to aid in the design and analysis of the gravity and lateral system. Ram will be used to aid in design of the gravity system and ETABS will be used for design and analysis of the lateral force resisting system. Topics discussed in Earthquake Resistant Design of Buildings will be used when designing the lateral system as a whole and specifically to design concentric, eccentric, and moment frames to resist lateral loads in combination with the existing reinforced masonry shear walls around stairwell shafts.

### **Breadth 1: Architecture/Structural Redesign Considerations**

The first breadth topic will involve how the architecture is affected by the structural redesign. Because the building was moved to a high seismic region the masonry bearing walls will be eliminated and a steel frame structure with precast concrete planks will replace it. With the new steel frame there will be columns coming down in the architectural plan. Bay sizes and column placement will be investigated to minimize disturbance to existing conditions. Other elements in the building may also have to be slightly rearranged to accommodate the new structure. The building layout will also be slightly affected by the isolation gap between the two separate wings.

### **Breadth 2: Cost and Schedule**

The second breadth topic is in the field of construction management. A large portion of cost is dependent on the building's structure and how quickly and easily it can be constructed. The proposed system's cost and schedule will be compared to that of the existing. The floor system will remain similar, except for the extra time and money to add a topping to the precast planks after being placed. Steel erection cost and time will be compared to that of laying reinforced concrete masonry shear walls. This comparison will help to show the added expense of designing for high seismic loads.

## Tasks and Tools

### Structural Breadth/MAE

#### Design of Steel Structure (RAM/ETABS/AE 538)

- Create RAM model to design gravity system
  - Determine new gridlines and placement of columns
    - Consider design of wings as separate structures
  - Determine dead and live loads in accordance with ASCE 7-05
  - Apply loads to levels correctly
  - Determine steel member sizes
  - Spot checks by hand based on load and tributary area of elements
- Consider building shape and ideal locations for lateral force resisting elements
  - Consider building shape and the isolation of the two building wings
  - Determine ideal locations for lateral force resisting elements
- Create ETABS model to design and analyze lateral system
  - Setup new gridlines determined for RAM model
  - Apply new lateral loads
  - Layout new lateral force resisting elements
  - Determine if lateral elements are adequate

#### Steel Concentric Braced Frames, Eccentric Braced Frames, and Moment Frames (AE 538/AISC Steel Construction Manual – 13<sup>th</sup> Ed./AISC Seismic Design Manual)

- Determine new seismic design load
  - Recalculate building weight
  - Determine seismic values for site location and structural system type
  - Calculate seismic base shear and story shears
- Design concentric braced, eccentric braced, and moment frames were appropriate
  - Determine which type of frame works best given location and architecture
  - Apply controlling lateral loads
  - Determine rough member size for input into ETABS lateral model
  - Detail 2-3 specific frames

## Breadth 1

### Architecture/Structural Redesign Considerations

- Determine new column layout
  - Adjust bay size to keep columns in existing walls
- Account for new columns in plan
  - Make needed architectural changes
- Considerations due to isolation gap between building wings
  - Room layouts
  - Elements that go through isolation gap
- Miscellaneous considerations
  - Ceiling
  - New layout of elements around structure

## Breadth 2

### Cost and Schedule (R.S. Means Data/MS Project)

- Determine cost and schedule of existing structural system
  - Ask CM about any available cost and schedule data for existing system
  - Determine any unavailable data using RS Means
- Determine cost and schedule of proposed structural system
  - Determine cost and schedule data for proposed structure using RS Means
  - Create a schedule for proposed structural system in MS Project
- Compare the effect the location change will have on cost and schedule of structure
  - Compare cost data
  - Compare schedule data

## Miscellaneous

- Comparison of the effect of seismic region on structural design
- Compare the use of separation joint to no separation joint
- Organize and write final report
- Prepare for final presentation
- Update website



## **Schedule**



